M2200-8

Thermal Chart Recorder

User Guide

SECTION 2 - DESCRIPTION

2.1 General Description

The M2200-8 Recorder is designed to accept signals from virtually any type of sensor such as Pressure Transducers, Thermocouples, Strain Gauges, Flow Meters, or Accelerometers, and to present these signals in a form suitable for analysis. The signals may also be recorded digitally for final output to analysis equipment via an RS232c port. There is also a connection for remote operation, while an internal back up supply allows the memory to store data for up to 12 hours.

The Recorder can accept up to 8 signals and present them on heat sensitive paper. The traces may be fully overlapping (i.e. each channel can write across the full chart width), or non-overlapping, on roll paper.

The Recorder may be installed either for dedicated use, or be used for visual data analysis during testing of systems on site. The internal memory is equivalent to up to 32 metres of recording paper on all channels (with full extended memory).

2.2 Detailed Description

The M2200-8 Recorder may be divided into 3 major parts. These are:

- The Signal Conditioning Modules which receive the analog signals from the external transducers, and transmit these to:
- The Data Acquisition/Analysis modules which convert these signals into digital form which can be processed and transmitted to:
 - a) External Devices. e.g. Computers
 - b) The paper chart
- The Mainframe, which houses the above.

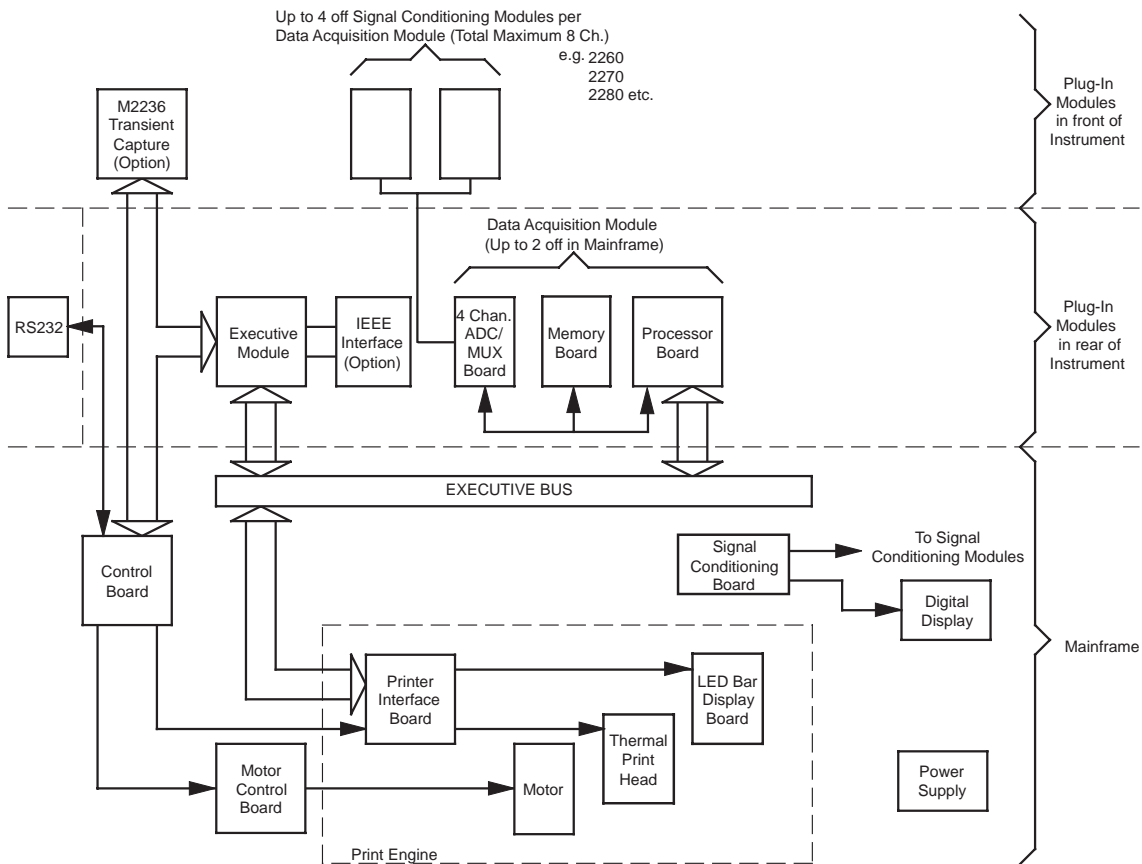

Figure 2-2 Block Schematic of Recorder

The Data Acquisition Module consists of three printed circuit boards:

- 4-Channel ADC/MUX

This board accepts 4 separate analog inputs, multiplexes these to a high speed 12 bit A/D converter and contains all the housekeeping logic for the module.

- Memory

Standard - 512 k-bytes providing 64k samples per channel.

Extended - up to 2 M-bytes of battery backed-up static RAM, partitioned to provide up to 256k samples per channel.

SECTION 3 - SET UP

3.1 Installation

The M2200-8 Recorder is portable and therefore is not dedicated to one installation point. During use there are some simple precautions to follow if the recorder is to operate safely and correctly.

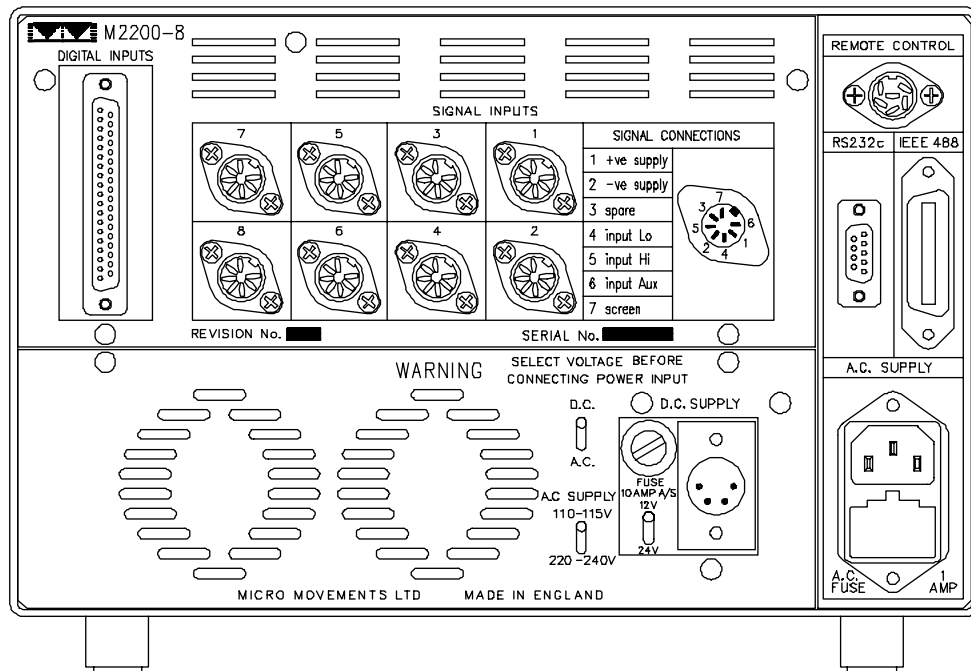

Figure 3-1 Rear View of M2200 Recorder (shown with A6 inverter).

- The dust cover must always be fitted when the recorder is not in use. Dirt and dust will cause undue wear on moving parts.
- The recorder must always be mounted on a secure flat surface, with sufficient space left at the rear, so that cooling air can escape from the vents, which are below the signal connection points. (see Figure 3-1)
- Always disconnect all the input connections, especially the power supply, before removing the recorder from its case. The recorder should not be removed from its case, except by properly qualified personnel.

The following parts are supplied with the recorder:

- AC and DC (if A6 inverter option fitted) power cables.
- One 7 pin connector for each Signal Conditioner supplied.
- Dust cover.
- Instruction manual.
- M2000.exe disk for computer interface.

3.2 Preparing for use

3.2.1 Basic set up

- a) Ensure the power switch is in the 'OFF' position.
- b) Select the voltage of the power source by the 3 toggle switches on the rear of the recorder. The switch settings are, AC/DC, 115/230 volts, and 12/24 volts. The voltage input ranges are:

AC - 115/230V 45 - 440 Hz.

Note: The frequency of the power source does not affect the recorder operation.

DC - 12V and 24V (This setting will also accommodate a 28V aircraft supply).

- c) Connect the power source to the appropriate socket on the recorder. Viewed from the rear the left hand, 4 pin socket is for the DC supply, the right hand, 3 pin IEC socket for the AC supply.



WARNING

IF BOTH INPUTS ARE CONNECTED AT THE SAME TIME DAMAGE MAY RESULT.

- d) Connect the 7 pin connectors to the signal input points.
- e) Connect the remote control cable if it is required to be used.
- f) Connect the computer control cable for RS232 serial connection if required.

3.2.2 Module DIL switches

The exact mode of operation of the recorder is determined by the positions of the DIL switches on the following boards:

(a) Channel Processor board

The DIL switches determine the channel number printed on the paper output. These are set up when the recorder is supplied to correspond to the channel input numbers.

	SW1	SW2	SW8
Channels 1-4	OFF	OFF	-
Channels 5-8	ON	OFF	-
Line Annotation	-	-	OFF
Edge Annotation	-	-	ON

(b) Executive Processor board

The executive board is normally set up to give memory recording in real time enabled, auto replay in record time disabled, and the language option set to English unless otherwise stated. These switches are located on the rear edge of the board.

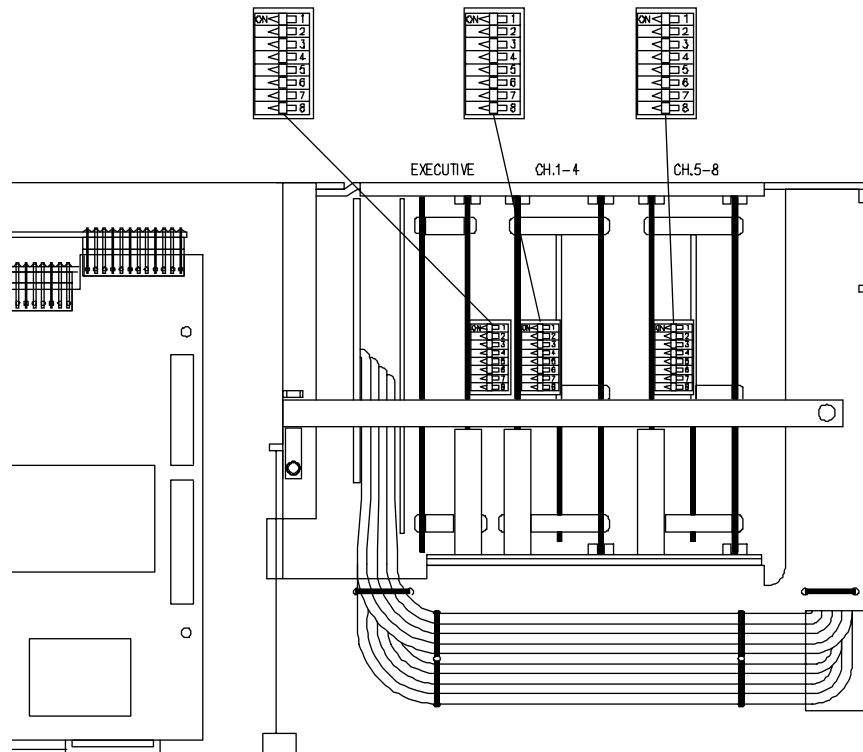

Figure 3-2 Executive and Channel Processor board DIL switch location

	SW1	SW2	SW3	SW4
memory recording				
in real time				
disabled	OFF	-	-	-
enabled	ON	-	-	-
auto replay				
in record time				
disabled	-	OFF	-	-
enabled	-	ON	-	-
language options				
English	-	-	OFF	OFF
French	-	-	ON	OFF
German	-	-	OFF	ON

(c) Control board

The DIL switches on the control board set up the baud rate for communication to an external computer. This is normally set up to 9600 baud and the switches can be found on the control board.

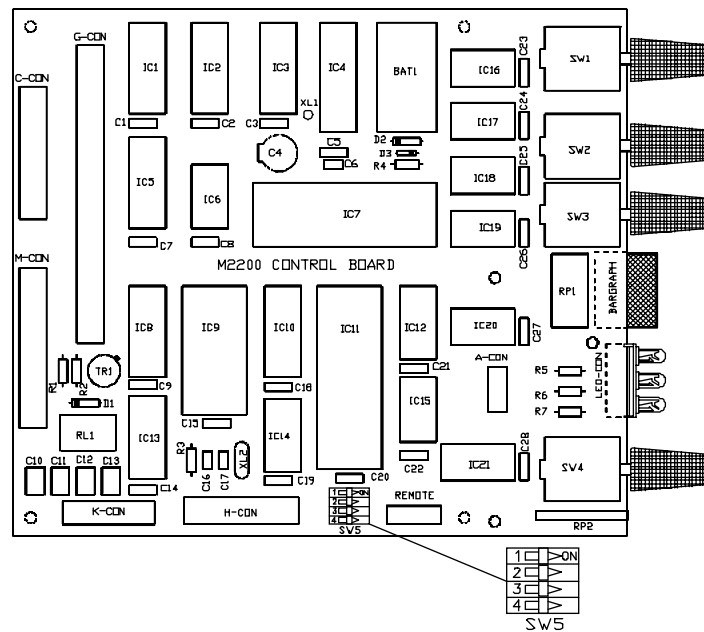

Figure 3-3 Control board DIL switch location

Baud Rate	SW1	SW2	SW3	SW4
19200	ON	ON	ON	ON
9600	ON	ON	ON	OFF
4800	OFF	ON	ON	OFF
2400	ON	ON	OFF	OFF
1200	OFF	OFF	ON	OFF

3.2.3 Operating Controls

Set the operating controls on the front of the recorder to suit the requirement. Check that there is sufficient paper and that it is correctly loaded (see section 4).

3.2.4 Switching on

Press the power switch to the ON position, Press the recessed RESET button to clear the memory if required. The recorder should now be ready for use.

3.2.5 Signal input connections

The 7 pin connections for the input signals to the conditioning units must be correctly wired. Signal input pin connections are:

- Pin 1 Transducer supply +ve
- Pin 2 Transducer supply -ve
- Pin 3 Not connected
- Pin 4 Input Low
- Pin 5 Input High
- Pin 6 Auxiliary supply/input
- Pin 7 Chassis

If there is any doubt about connection details, contact the Technical Service Department of **Micro Movements**. (see Service Guide for details).

SECTION 4 - OPERATION

The Recorder is set to suit the particular needs of the job before starting to record data. The controls described in this section are adjusted to set the recorder for use. Their operation in most cases is self evident, however some details need explanation. A simple guide to the operation of the recorder is given in the following paragraphs. More detailed information on the operation of the controls can be found later in the section. Figure 4-1 shows the front view of the recorder.

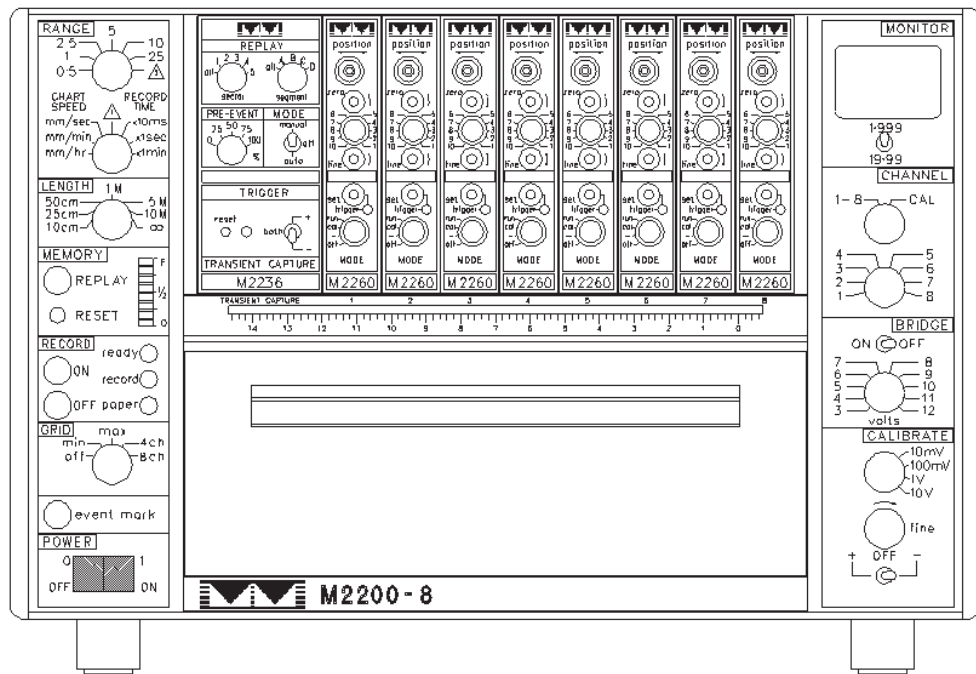

Figure 4-1 Front Panel of Recorder

4.1 Basic Operation

The M2200 Thermal Printer Recorder can operate in two clearly defined modes, Real Time mode and Record Time (storage) mode, with some overlapping facilities. In Real Time mode data is gathered and printed simultaneously. In Record Time mode data is gathered and stored for later analysis.

In Real Time mode, after the Record ON button has been pressed the recorder will automatically start to gather data and print. In Record Time mode, when the Record ON button has been pressed data is gathered for the set Record Time and, when this is complete, automatically printed (if auto replay is enabled on the Executive board DIP switches - see Section 3.2). In each case pressing the REPLAY button will print out the data stored in memory.

4.1.2 Record Time Operation

- a) Select the required record time.

The Range/Mode selector switch is set to one of the switch positions marked 'RECORD TIME' (x10 ms, x1 sec or x1 min). In these three positions data is captured in memory for subsequent replay to the Chart or to an external device, e.g. a Computer. There are a total of 17 Record Time Data Capture positions ranging from 10 milliseconds to 25 minutes. The sampling frequency and stored data rate is shown in Tables 4-4 and 4-5.

- b) Select the printing length.

The Chart length switch is set to the approximate length required for the recording. The recorder automatically selects a suitable scale and prints the chart length to suit the memory size and sampling rate (if auto replay is enabled on the Executive board DIP switches - see Section 3.2). The maximum length of paper printed out is 50cm.

- c) Set the signal conditioning controls.

These settings depend on the type of signal conditioning modules fitted and the results required. A quick guide to setting the signal conditioning controls is given in Section 4.1.3. Details of the mainframe controls used are given in this section while details of the module controls are given in the module user guide.

- d) Press Record ON.

The recorder operates for the selected time, storing data in memory. The minimum sampling rate is 16kHz, resulting in a minimum bandwidth of 2kHz. The maximum sample rate is 80kHz, giving a bandwidth of 10kHz. The data is stored in memory (see Section 4.3 for further details) and can be replayed and expanded on to paper, or downloaded to a host computer as described in Section 5 (or both if required).

4.1.3 Setting the Signal Conditioning Modules

Each Signal Conditioning module has to be set for the particular sensor which is being monitored. The following paragraphs describe, in general terms, the sequence of operations required when setting up a signal conditioning module. Further details on individual module controls and calibration method are given in the module user guides.

Note. As each Signal Conditioning Module is set up for its connected sensor, it is important that the connection cables are labelled to make sure that future reconnections are made correctly. This ensures that only minor adjustments are required for calibration.

4.1.4 Paper Loading

When the PAPER lamp is lit, to indicate that the paper has run out, the printer operation is inhibited. After a new roll of paper has been loaded, pressing the REPLAY button allows the printing operation to be completed.

IMPORTANT – The thermally sensitive paper must be carefully stored away from heat and light, so that it remains in first class condition for use.

- a) Pull the handle on the paper tray so that the flap falls forward.
- b) Remove the old paper spool.
- c) Drop in the new paper roll and pull out a short length of paper, so that it projects over the lip of the paper flap.

Note: that the spool is positioned so that the thermally sensitive (glossy) side of the paper is uppermost.

- d) Close the flap. The PAPER lamp is extinguished and the READY lamp is lit.

To tear off the paper, pull the paper upwards against the cutting edge of the fascia.

4.1.5 Messages

The messages which are automatically printed on the paper, are:

- a) Run number - Each run of printing is sequentially numbered along the left edge of the paper. The numbering is reset to start at run no. 1, when the recorder is switched on, or when the RESET button has been pressed.
- b) Chart Time Base - The chart speed as selected by the SPEED controls, is printed alongside the grid lines on the left edge of the paper in time base format. e.g. 1 sec/cm.
- c) Date/Time - The date and time of the run is shown along the left edge of the paper. The internal battery maintains the date/time information for over 6 months when the mains power has been removed.
- d) User Messages - A message can be printed along the right edge of the paper. This may consist of any 70 characters alpha/numeric title such as the company name, location, etc. The message is entered via the RS232c port on the back of the recorder. (see section 5).
- e) Event Marker - A point of interest during a recording run may be marked on the right edge of the paper by pressing the EVENT MARKER button. The mark is printed for the duration of the button being pressed. When the recorder is in a standby mode pressing the EVENT MARKER button outputs a sampling information table (see Section 4.2.1).
- f) The channel number of the trace is printed automatically every 20cm along the line of trace.

Range Multiplier Switch

This is a 7 position switch used in conjunction with the Range Selector switch. Position 7 of the switch is not used. The range steps available are, 0.5, 1, 2.5, 5, 10 and 25.

Range/Mode Selector Switch

This is a 7 position switch used in conjunction with the Range Multiplier Switch. This switch gives:

- 3 Chart Speed ranges for real time recording (mm/sec, mm/min, mm/hr)
- 1 Spare position. (marked '!')
- 3 Record Time ranges for high speed data capture (x10 ms, x1 ms, x1 min)

Using this switch with the Range Multiplier switch the following ranges can be selected:

Switch Position	Mode/Range selected
1 (mm/hr)	Real Time Chart Recorder 0.5 to 25mm/hr
2 (mm/min)	Real Time Chart Recorder 0.5 to 25mm/min
3 (mm/sec)	Real Time Chart Recorder 0.5 to 25mm/sec
4 (!)	Not Used
5 (x10 msec)	Record Time Capture Mode - 10 to 250 milliseconds.
6 (x1 sec)	Record Time Capture Mode - 0.5 to 25 secs.
7 (x1 min)	Record Time Capture Mode - 0.5 to 25 mins.

Chart Length Switch

This switch controls the Chart length of a record. This is a 7 position switch, the lengths available are:

Switch Pos.	Compression Ratio
10cm	10:1
25cm	5:1
50cm	2:1
1m	1:1
5m	1:2
10m	1:4
Infinity	1:4

Reset Push Button

This is a recessed push button, that will clear the memory when pressed.

Record Box

This box contains the Record ON and OFF buttons and the three LED indicators:

Ready - A green LED that indicates the recorder is ready to record.

Record - A red LED that indicates a recording is in progress.

Paper - A red LED that indicates the paper requires changing.

The Record ON button starts the recording in either Real time or Record time modes. The Record OFF button stops the recording immediately in either mode, although this function is not generally used for record times of less than 5 seconds.

When the Record ON button is pressed in record time mode, the Record LED lights up and the memory starts to fill up. The recorder stays on for the time set by the combination of the range multiplier switch and the range/mode selector switch, (unless the record is interrupted by the Record OFF function). After the ON time has elapsed, all LED's will be illuminated, showing that the memory is full, and the green 'ready' LED will illuminate. To output the paper, the required length is set, and the REPLAY button pressed. The recorder will automatically set the required scale to fit the stored data into the selected paper length. If the auto replay DIP switch (on the Executive board) is enabled the stored data is printed out immediately after the memory is filled.

Grid

The 5 position grid switch provides the following selection of grids:

Switch Position	Function Legend	
1	off	Grid Off
2	min	Heavy 1cm grid with 1mm divisions all 8 channels overlapping
3	max	As the minimum grid with an additional fine 2mm grid
4	4 ch	Print out channels 1-4 split into 4 sections, each section 3cm
5	8 ch	Print out channels 1-8 split into 8 sections, each section 1cm.

Stored data can be replayed with any selected grid.

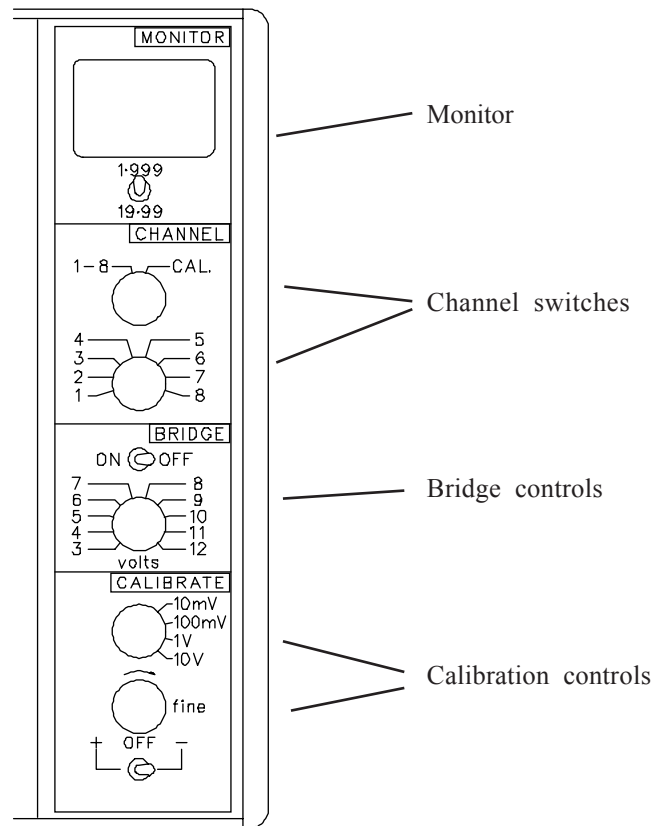

Figure 4-3 Right Hand Side Front Panel

Channel Switches

The top rotary switch is a 2 position switch, the first position selects the channel display, and the second position selects the calibrate display. The bottom rotary switch is an 8 position switch, which selects the channel number to be displayed when the top switch is in the first position.

Bridge Controls

This function injects a transducer power supply into the channels. The toggle switch turns this feature ON and OFF.

The rotary switch selects an accurate known voltage, from 3 to 12 volts DC, which is routed via the signal conditioning modules to energise external transducers.

4.3 Sampling, Storage and Replay Rates

4.3.1 Real Time Mode

In Real Time mode the sampling frequency and rate of data storage depends on the CHART SPEED switch settings as shown in Table 4.1. The replay characteristics are shown in Tables 4.2. and 4.3.

CHART SPEED	INPUT SAMPLING	DATARATE TOMEMORY	DATARATE TO PAPER	TIMETOFILL 256K MEMORY
mm/sec	KHz	Samples/sec	Dots/sec	Mins
25	6.25	800	200	2.67
10	6.25	320	80	6.67
5	6.25	160	40	13.33
2.5	6.25	80	20	26.67
1	6.25	32	8	66.67
0.5	6.25	16	4	133.33
mm/min		Samples/min	Samples/min	Hours
25	6.25	800	200	2.67
10	6.25	320	80	6.67
5	6.25	160	40	13.33
2.5	6.25	80	20	26.67
1	6.25	32	8	66.67
0.5	6.25	16	4	133.33
mm/hr		Samples/hr	Samples/hr	Days
25	6.25	800	200	6.67
10	6.25	320	80	16.67
5	6.25	160	40	33.33
2.5	6.25	80	20	66.67
1	6.25	32	8	166.67
0.5	6.25	16	4	333.33

Table 4-1 Real time sampling frequencies and stored data rates

When running in Real-time the memory fills with four data points for every one printed on the paper. The memory fills until 4 Metres of paper are printed (1 Metre for 64K of memory). The memory then starts overprinting while the paper continues printing in Real-time. Thus after 4 metres is printed the memory always holds the last 4 metres available for replay.

4.3.2 Record Time Mode

In Record Time mode the sampling frequency and rate of storage of data in memory is chosen by the recorder to maximise the bandwidth for the selected record interval. To achieve this two methods of storage are used:

- a) Direct storage mode
- b) Compressed storage mode

Direct storage mode

With this method all samples are stored directly in memory. Thus the sampling rate is the same as the data to memory rate. All samples are stored and the sampling rates are from 10 msec to 2.5 secs (10 secs with extended memory).

Direct storage mode applies to shorter record times. As the record time increases, the amount of memory required to hold the samples exceeds the available memory. Compressed storage mode is then used.

Compressed storage mode

In this mode the sample rate is at a constant 16kHz, but the data is compressed before being stored in memory. This method ensures that a high bandwidth is retained at longer record times without overflowing the available memory.

Data compression is achieved by recording the maximum and minimum sample values over a defined period. This period is variable depending on the record time selected. Each maximum/minimum value is known as a data point. These data points are stored in memory.

The sampling rate is always 16kHz but the number of samples used to form a data point is variable depending on the record time selected. For longer record times more samples are used to calculate one data point otherwise the memory would overflow. Alternatively, the time period over which the samples values are collated is extended. Thus for long record times the rate of storage of data points to memory is reduced preventing memory overflow.

From the tables it can be seen that the system can be considered to operate in four bands. Extended memory figures are in brackets.

- Band 1. 10 msec to 0.5 sec(10 msec to 2.5 sec) - Maximum Sampling Frequency (80kHz). All samples stored.
- Band 2. 1 sec (5 sec) - Reduced Sampling Frequency (40kHz). All samples stored.
- Band 3. 2.5 sec (10 sec) - Reduced Sampling Frequency (16kHz). All samples stored.
- Band 4. 5 sec to 25 min (25 sec to 25 min) - Fixed sampling frequency of 16kHz samples compressed to give a lower data rate to memory whilst retaining the bandwidth.

The minimum sampling rate is 16kHz, resulting in a minimum bandwidth of 2kHz. The maximum sample rate is 80kHz, giving a bandwidth of 10kHz. The data is stored in memory as defined in Tables 4.4 and 4.5, and can be replayed and expanded on to paper, as defined in Tables 4.6 and 4.7, or downloaded to a host computer as described in section 5 (or both if required).

Record Switch Setting	Compression on Replay Chart Length Switch Setting						
	10cm	25cm	50cm	1M	5M	10M	Infinity
5 ms	1	1	1	1	1	1	1
10 ms	1	1	1	1	1	1	1
25 ms	2	1	1	1	1	1	1
50 ms	5	2	1	1	1	1	1
100 ms	10	4	2	1	1	1	1
250 ms	25	10	5	2	1	1	1
0.5 sec	50	20	10	5	2	1	1
1 sec	50	20	10	5	2	1	1
2.5 sec	40	20	10	4	2	1	1
5 sec	25	10	5	2	1	1	1
10 sec	40	20	8	4	2	1	1
25 sec	20	10	5	2	1	1	1
0.5 min	20	10	5	2	1	1	1
1 min	25	10	5	2	1	1	1
2.5 min	20	10	4	2	1	1	1
5 min	20	10	5	2	1	1	1
10 min	25	10	5	2	1	1	1
25 min	20	10	4	2	1	1	1

Table 4-6 Record time replay compression characteristics for standard memory recorders

No further expansion is possible once the compression is 1. Selecting a longer paper length will not result in more paper being printed out. For short record times little or no compression is performed as the memory holds a limited number of samples.

SECTION 5 - COMMUNICATION

The connection points on the rear of the M2200-8 Recorder are used for communication with:

- a) An external Main Frame Computer or PC via an RS232c port.
- b) An external Main Frame Computer or PC via an IEEE 488 port. This port is a factory fitted option.
- c) A remote control device.

5.1 RS232c

The communications via the RS232 port (fitted as standard on all instruments) enables the following functions to be performed:

- a) Setting the date and time of the clock.
- b) Entering a message to be printed on the right hand edge of the paper.
- c) Accessing data stored in the recorder. The simplest way of accessing the memory of the recorder is to use the disc supplied with the instrument. The disc contains a menu driven program M2000.EXE. When this is loaded on a host computer, RS232 ports connected and the recorder supply turned on, execution of the program will bring up a self-help menu on the computer screen to enable the above functions. The disc is PC AT compatible. The RS232 serial link is preset on the control board for a Baud rate of 9600, with 8 Data Bits, 1 Stop Bit and no parity.

NOTE: Check that the COM port on the PC is set for the same baud rate as the recorder. To set the PC, from the C prompt, type `mode comx: 9600,n,8,1` then press enter. (Where x is 1 or 2 depending on the com port connected to the recorder).

5.1.1 M2000.EXE Program

The M2000.EXE program brings up a simple menu on the PC screen. The options available allow the required channel to be selected, channel data to be logged and converted, the real time clock within the recorder to be set and a message of up to 80 characters to be input for printing along the right hand side of the paper.

The cursor keys are used to position the highlight over the option required and the ENTER key used to select the option.

Set all channels

Used if all channel data is to be logged. Highlights all channels in the left hand section of the screen.

Set real time clock

This option allows the clock in the recorder to be set to that of the PC. When selected the date and time from the PC are downloaded to the recorder and also echoed on screen as confirmation.

Set variable message

This option allows a message of up to 80 characters to be downloaded to the recorder for printing along the right hand side of the paper.

5.1.2 Microlog 2000 Program

Microlog 2000 is a Windows version of M2000.EXE. It allows the user to perform all the functions of the M2000 program from within the windows environment and in addition allow more control over how the down loaded data is stored. See the Microlog 2000 Manual for further details.

5.1.3 Protocol For M2200 RS232 Link

The M2200 responds to various commands sent on the RS232 link for data logging, setting the real time clock and inputting a variable message. Commands are initiated by sending a single character of any ASCII value. A three letter command is then sent which is followed by data specific to each command.

*SCK - Set Clock

The set clock command is sent, followed by the date and time in the following format:-

*SCK Day Month Year Hour Minute Second

e.g. *SCK290193093422 is date 29 Jan 93
time 09:34:22

The SCK command must be followed by twelve ASCII characters. If less than twelve are sent the M2200 waits for the remainder and eventually times out, in which case the clock will not be set.

*SVM - Set variable Message

The set variable message command is sent followed by the variable message itself which may be up to 80 characters and is terminated by a carriage return character (0d hex).

e.g. *SVMTest Message for M2200(0d)

5.3 Remote Control

A six pin DIN socket enabling remote contact closure to initiate Record ON and Record OFF.

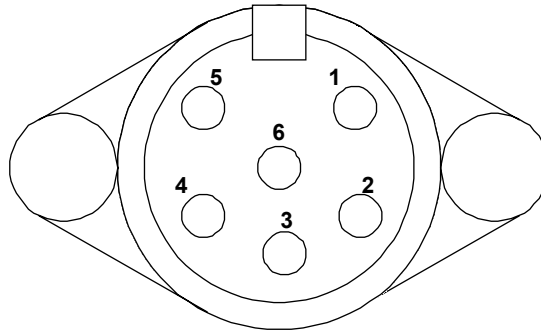

The pin layout of the connector is shown above and the connection details are as follows:

Pin 1	Record Off
Pin 2	Event
Pin 3	Record On
Pin 4	Record Cath
Pin 5	GND
Pin 6	VCC